



德國GEKO流體控制有限公司
GEKO Fluid Control GmbH

▶ 台灣蓋科閥業股份有限公司

地址:台中市后里區復興街36巷10號
電話: +886-4-25565626
傳真: +886-4-25569580
網址: www.geko.com.tw
郵箱: sales@geko.com.tw

▶ Taiwan Geko Valve Co.,Ltd.

Address:NO.10,Ln.36,Fuxing St.,
Houli Dist.,Taichung City 421,Taiwan
Tel: +886-4-25565626
Fax: +886-4-25569580
URL: www.geko.com.tw
E-mail: sales@geko.com .tw

▶ GEKO中國代表處

地址: 常州市青洋北路101號美吉特商務大廈16F
電話: 0519-85503155 / 85503955
傳真: 0519-85503133
網址: www.geko-valves.com
郵箱: geko@geko-valves.com

▶ GEKO office in China

Address: 16th Floor Megete Building, No.101 Qiyang
North Road, Changzhou 213000, P.R.China
Tel: 0519-85503155 / 85503955
Fax: 0519-85503133
URL: www.geko-valves.com
E-mail: geko@geko-valves.com



www.geko-valves.com

德國GEKO流體控制有限公司

GEKO Fluid Control GmbH

High Performance Pneumatic Actuators
Control Valve Accessories

氣動執行器及控制閥附件

+ 更多詳情資訊請登錄蓋科公司網頁或致電本公司

May. 2013. 3000





ABOUT GEKO FLUID CONTROL GMBH

經驗、責任和領先的技術



GV enterprise Co., Ltd. was found in 2002. GV consists of professional developers, designers, production personnel, and quality control personnel with years of experience. We devote all our energy to combine advanced technologies. We integrated CNC lathes, CNC internal machining, plastic injection, precision casting, aluminum and zinc die casting, and stamping mechanical equipment (Equipment with operating programs :

Computer-aidedDesign→Purchase→Feed→Production Process→Assembly→Quality ControlService). Brand OEM integrates global resources intomarket, in order to provide better services for our customers.

Under strict quality control, TUV, ISO9001 quality assurance standards, and the pursuit of zero defect managements, they have made our OEM and ODM adopted by world renowned petrochemical industry, optoelectronics industry, biotechnology medical,semiconductor, and electronic chemical manufacturing .The current customers are Sinopec, PetroChina, CNOOC, China Shenhua, China Coal, China Guodian Corporation, China Car, Vietnam power plant, including GEKO, Omal, SFVetc. Our high self-request standards make us maintain the advantages of the international market, and ultimately our products will be widely used in the world-renowned enterprises, such as GE, TYCO, GEA, HITACHI, TOYO, POSCO, Samsung, ABB, TOTAL, BP, BASF, DOW, BAYER, ROCHE, LINDE, NOVARTIS, NESTLE, SYNGENTA, TATA STEEL.

In 2016,to meet diverse needs of the customers around the world, Germany GEKO buy shares into GV. We officially changed our name to Taiwan Geko Valve Corporation. We are in charge of the markets in Taiwan, Japan, Korea, and other countries in Southeast Asia and the agency of product sales network. Relying assembly and testing center in China, we will provide better services in Asian market.



德國GEKO流體控制有限公司

Scope of Supply



Pneumatic Actuator

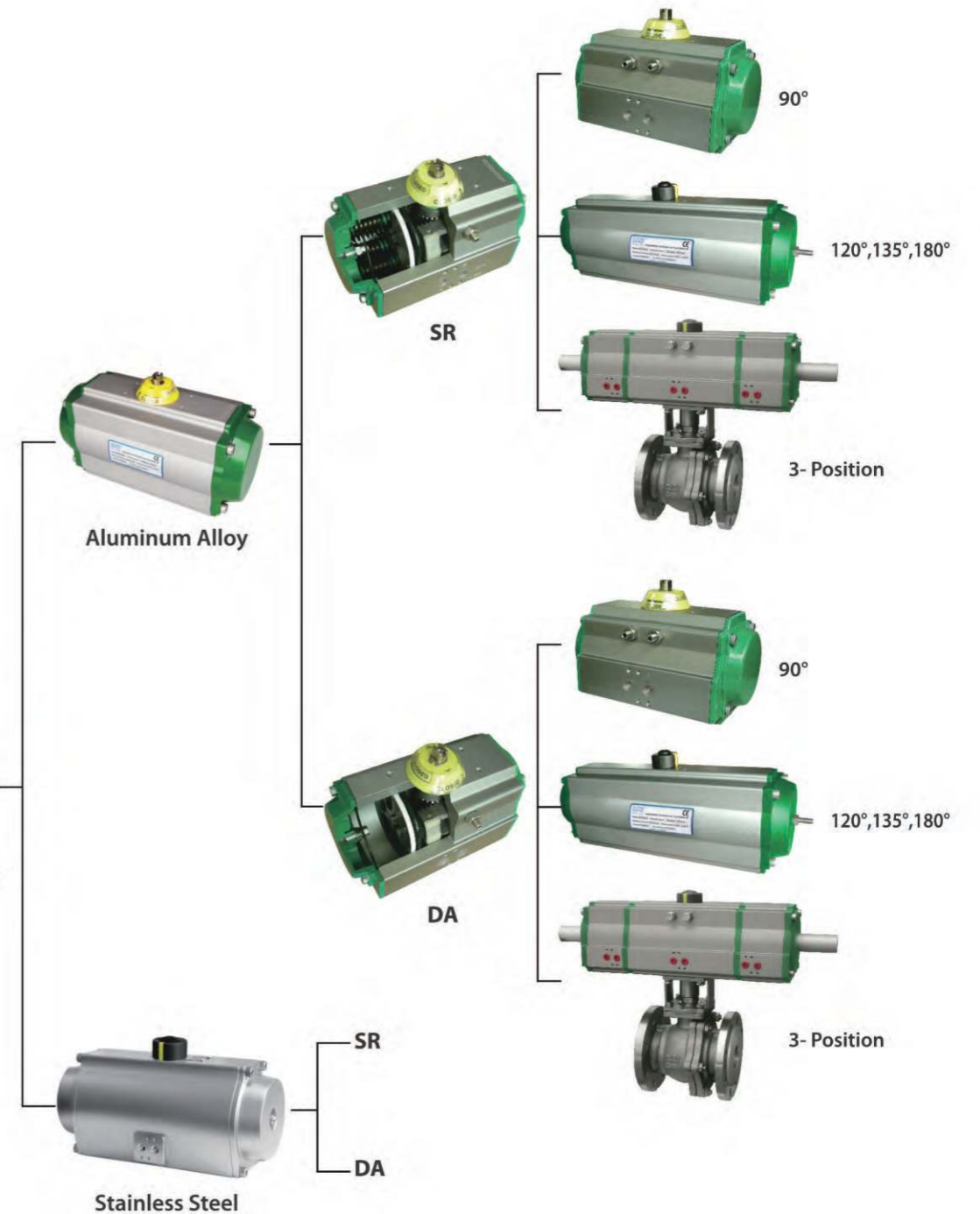

Indicator



1. Hard anodized body

According to the different requirements, the extruded aluminum alloy ASTM6005 Body can be treated with hard anodized, powder polyester painted (different colours is available such as blue, orange, yellow etc.), PTFE or Nickel plated.

2. Rack pistons

The twin rack pistons are made from Die-casting aluminum treated with Hard anodized or made from Cast steel with galvanization. Symmetric mounting position, long cycle life and fast operation, reversing rotation by simply inverting the pistons.

3. Travel stop adjustments

The two independent external travel stop adjustment bolts can adjust $\pm 5^\circ$ at both open and close directions easily and precisely.

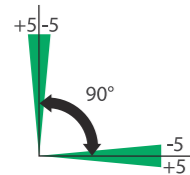

4. O-rings

NBR rubber O-rings provide trouble-free operation at standard temperature ranges. For high and low temperature applications Viton or Silicone.

5. Pinion

The pinion is high-precision and integrative, made from nickelled-alloy steel, full conform to the latest standards of ISO5211, DIN3337, NAMUR. The dimensions can be customized and the stainless steel is available.

6. End caps

Die-casting aluminum powder polyester painted in different colours, PTFE or Nickel plated.

7. High performance springs

Preloaded coating springs are made from the high quality material for resistant to corrosion and longer service life, which can be demounted safely and conveniently to satisfy different requirements of torque by changing quantity of springs.

8. Bearings & Guides

Made from low friction, long-life compound material, to avoid the direct contact between metals. The maintenance and replacement are easy and convenient.

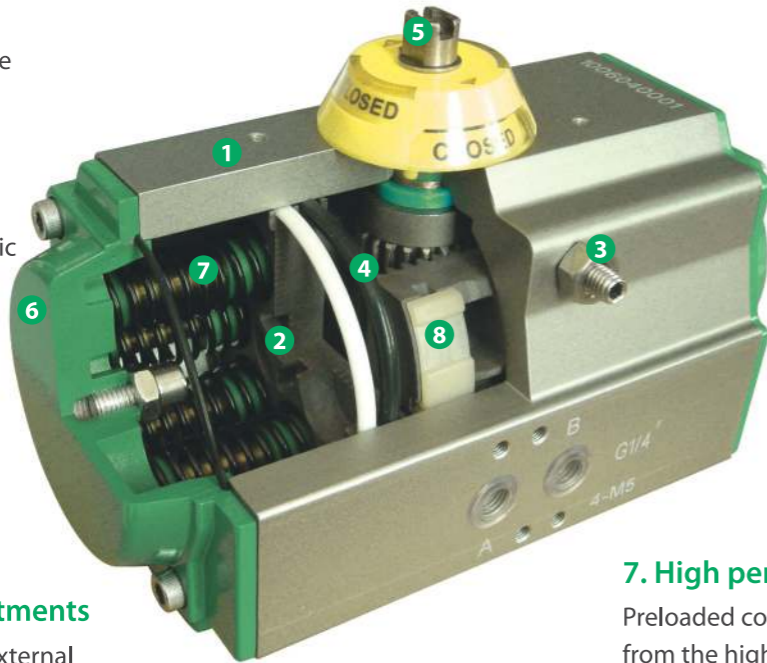

Double Acting Actuators

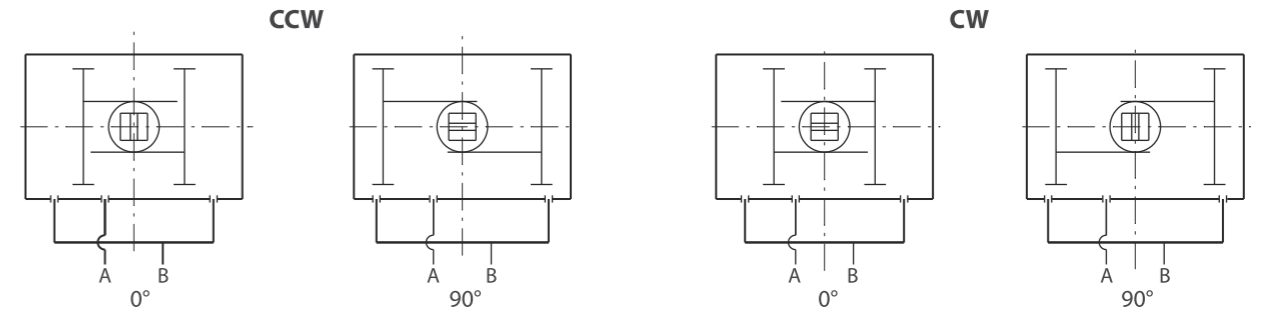

Air to Port A forces the pistons outwards, causing the pinion to turn counterclockwise while the air is being exhausted from Port B.

Air to Port B forces the pistons inwards, causing the pinion to turn clockwise while the air is being exhausted from Port A.

Air to Port A forces the pistons outwards, causing the pinion to turn clockwise while the air is being exhausted from Port B.

Air to Port B forces the pistons inwards, causing the pinion to turn counterclockwise while the air is being exhausted from Port A.

Spring Return Actuators

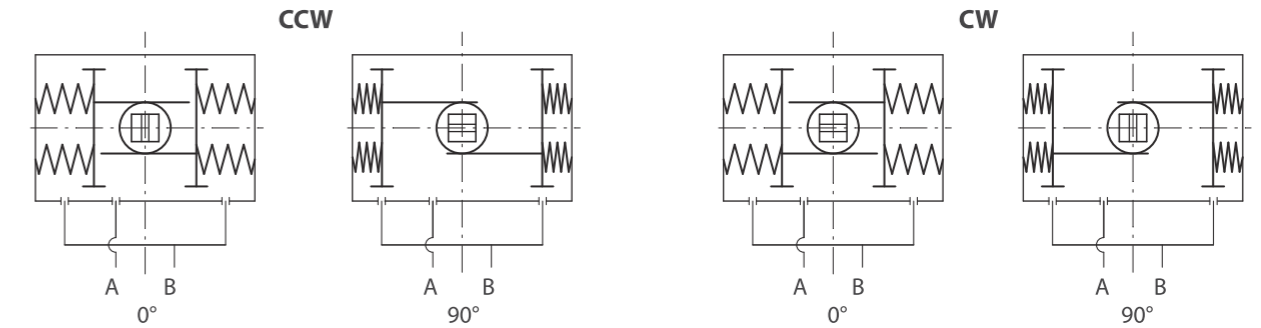

Air to port A forces the pistons outwards, causing the springs to compress, The pinion turns counterclockwise while air is being exhausted from port B.

Loss of air pressure on port A, the stored energy in the springs forces the pistons inwards. The pinion turns clockwise while air is being exhausted from port A.

Air to port B forces the pistons outwards, causing the springs to compress, The pinion turns counterclockwise while air is being exhausted from port B.

Loss of air pressure on port A, the stored energy in the springs forces the pistons inwards. The pinion turns clockwise while air is being exhausted from port A.

Operating Conditions

1. Operating media

Dry or lubricated air or the non-corrosive gases

The maximum particle diameter must less than 30 um

2. Air supply pressure

The minimum supply pressure is 2.5 Bar

The maximum supply pressure is 8 Bar

3. Operating temperature

Standard: $-20^\circ\text{C} \sim +80^\circ\text{C}$

Low temperature: $-35^\circ\text{C} \sim +80^\circ\text{C}$

High temperature: $-15^\circ\text{C} \sim +150^\circ\text{C}$

4. Travel adjustment

Have adjustment range of $\pm 5^\circ$ for the rotation at 0° and 90°

5. Application

Either indoor or outdoor

Output Torque of Double Acting Actuators

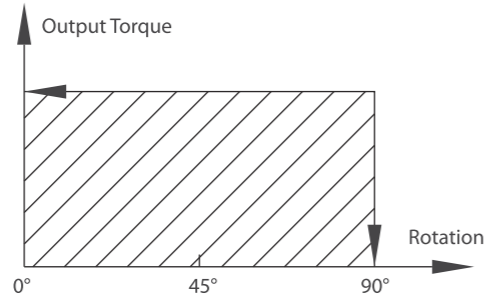

Unit: Nm

Model	Air supply pressure (Unit: bar)									
	2	2.5	3	4	4.5	5	5.5	6	7	8
GK007DA	3.1	3.8	4.6	6.1	6.9	7.6	8.4	9.2	10.7	12.2
GK012DA	4.8	6	7.2	9.6	10.8	12	13.2	14.4	16.8	19.2
GK020DA	8.0	10.0	12.0	16.0	18.0	20.0	21.9	23.9	27.9	31.9
GK035DA	14.6	18.2	21.9	29.2	32.8	36.5	40.1	43.8	51.1	58.4
GK050DA	20.1	25.1	30.1	40.1	45.1	50.2	55.2	60.2	70.2	80.3
GK075DA	31.4	39.2	47.0	62.7	70.5	78.4	86.2	94.1	109.7	125.4
GK110DA	45.1	56.4	67.7	90.3	101.6	112.9	124.1	135.4	158.0	180.6
GK160DA	66.1	82.7	99.2	132.2	148.8	165.3	181.8	198.4	231.4	264.5
GK255DA	100.3	125.4	150.5	200.6	225.7	250.8	275.9	301.0	351.1	401.3
GK435DA	171.0	213.8	256.5	342.0	384.8	427.5	470.3	513.0	598.5	684.0
GK665DA	266.0	332.5	399.0	532.0	598.5	665.0	731.5	798.0	931.0	1064.0
GK1000DA	425.6	532.0	638.4	851.2	957.6	1064.0	1170.4	1276.8	1489.6	1702.4
GK1200DA	532.0	665.0	798.0	1064.0	1197.0	1330.0	1463.0	1596.0	1862.0	2128.0
GK1800DA	769.5	961.9	1154.3	1539.0	1731.4	1923.8	2116.1	2308.5	2693.3	3078.0
GK2700DA	1169.6	1462.1	1754.5	2339.3	2631.7	2924.1	3216.5	3508.9	4093.7	4678.6
GK3800DA	1526	1908	2289	3052	3434	3815	4197	4578	5341	6104
GK5700DA	2285	2856	3427	4570	5141	5712	6283	6854	7997	9139
GK8000DA	3256	4070	4884	6512	7326	8140	8954	9768	11396	13024

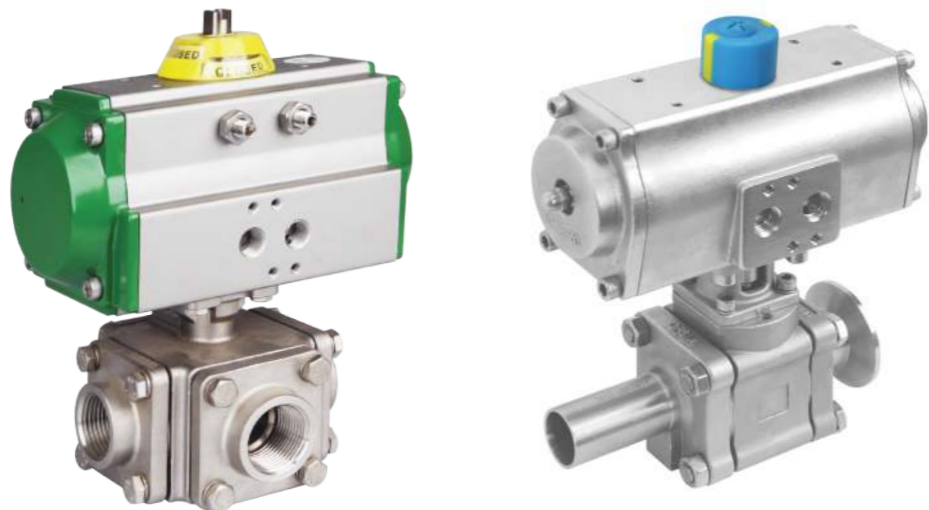

Output Torque of Spring Return Actuators

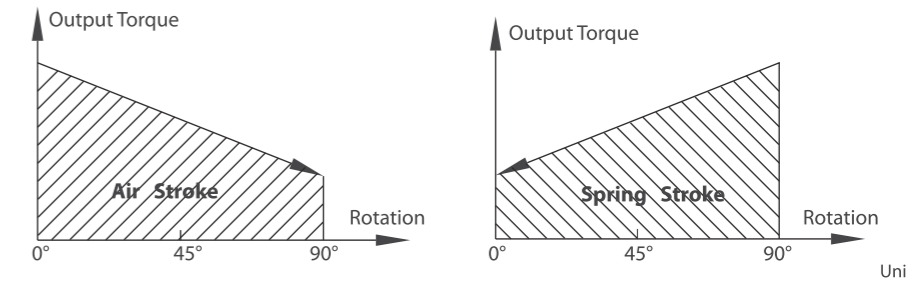

Unit: Nm

Air pressure	Model	Output torque of air to springs																
		Spring Qty.	2.5BAR		3BAR		4BAR		5BAR		6BAR		7BAR		8BAR		Springs' output	
		0°	90°	0°	90°	0°	90°	0°	90°	0°	90°	0°	90°	0°	90°	90°	0°	
		Start	End	Start	End	Start	End	Start	End	Start	End	Start	End	Start	End	Start	End	
2.5BAR	GK020SR	K5	5.7	3.8	7.6	5.7											6.2	4.3
2.5BAR		K6	4.9	2.5	6.9	4.5	10.9	8.5									7.4	5.0
2.5BAR		K7	4.0	1.3	6.0	3.3	9.8	7.3	14.0	10.4							8.6	5.9
2.5BAR		K8			5.2	2.0	9.2	6.0	13.2	9.1	17.2	14.1					9.9	6.7
2.5BAR		K9			4.3	0.8	8.3	4.8	12.3	7.9	16.3	12.8	20.3	16.8			11.1	7.6
2.5BAR		K10					7.4	3.6	11.5	6.7	15.5	11.6	19.5	15.6			12.4	8.5
2.5BAR		K11					6.6	2.3	10.6	5.4	14.6	10.4	18.6	14.3	22.6	18.3	13.6	9.3
2.5BAR		K12							9.7	4.2	13.8	9.1	17.8	12.2	21.8	17.1	14.8	10.2
3BAR	GK035SR	K5	11.4	7.7	15.0	11.4	22.3	14.9									10.4	6.8
3BAR		K6	10.1	5.7	13.6	9.3	20.9	16.6	28.3	23.9							12.5	8.2
3BAR		K7	8.6	3.6	12.5	7.2	19.5	14.5	26.8	21.9							14.6	9.6
3BAR		K8			10.9	5.1	18.2	12.4	25.5	19.8	32.8	27.0	40.1	34.3			16.7	10.9
3BAR		K9					16.8	10.4	24.1	17.7	31.4	24.9	38.7	32.2			18.8	12.3
3BAR		K10					1.4	8.2	22.8	15.6	30.0	22.8	37.3	30.1	44.7	37.4	20.9	13.7
3BAR		K11							21.5	13.5	28.7	20.7	36.0	28.0	43.3	35.3	22.9	15.0
3BAR		K12							20.0	11.4	27.3	18.6	34.6	25.9	41.9	33.3	25.0	16.4
4BAR	GK050SR	K5	14.5	10.6	19.4	15.5	29.5	25.7									14.5	10.5
4BAR		K6	12.4	7.6	17.3	12.6	27.4	22.7	37.5	32.8							17.4	12.7
4BAR		K7	10.4	4.8	15.2	9.7	25.3	19.9	35.4	29.9							20.3	14.8
4BAR		K8			13.1	6.8	23.1	16.9	33.3	27.0	43.2	37.0	53.3	47.0			23.2	16.9
4BAR		K9					21.0	14.1	31.2	24.1	41.1	34.1	51.2	44.2			26.1	19.0
4BAR		K10					19.0	11.1	28.8	21.2	39.0	31.2	49.1	41.2	59.1	51.2	29.0	21.1
4BAR		K11							27.0	18.3	37.0	28.3	47.0	38.4	57.0	48.4	31.9	23.2
4BAR		K12							24.9	15.4	34.9	25.4	44.9	35.4	54.9	45.4	34.7	25.3
5BAR	GK075SR	K5	23.3	16.1	31.1	24.0	46.8	39.7									23.0	15.8
5BAR		K6	20.1	11.5	28.0	19.3	43.7	35.1	59.4	50.7							27.6	19.0
5BAR		K7	17.0	6.9	24.8	14.8	40.5	30.5	56.2	46.2							32.2	22.1
5BAR		K8			21.7	10.1	37.4	25.8	53.1	41.5	68.8	57.2	84.5	72.9			36.8	25.3
5BAR		K9					34.2	21.3	49.9	37.0	65.6	52.6	81.2	68.3			41.4	28.5
5BAR		K10					31.0	16.6	46.7	32.3	62.4	48.0	78.1	63.7	93.8	79.3	46.0	31.6
5BAR		K11							43.6	27.7	59.3	43.4	75.0	59.1	90.6	74.8	50.6	34.8
5BAR		K12							40.4	23.2	56.1	38.9	71.7	54.5	87.4	70.2	55.2	38.0
6BAR	GK110SR	K5	33.1	22.0	44.2	33.2	66.8	55.9									34.4	23.3
6BAR		K6	28.4	15.2	39.6	26.4	62.2	49.0	84.8	71.6							41.2	28.0
6BAR		K7	23.8	8.2	34.9	19.4	57.5	42.1	80.2	64.7							48.1	32.7
6BAR		K8			31.3	12.6	52.9	35.2	75.5	57.9	98.1	80.5	120.7	103.0			55.0	37.3
6BAR		K9					48.2	28.4	70.9	51.0	93.5	73.6	116.0	96.1			61.9	42.0
6BAR		K10					43.6	21.5	66.2	44.1	88.8	66.7	111.3	89.2	134.0	111.8	68.7	46.7
6BAR		K11							61.5	37.2	84.1	59.9	106.6	82.4	129.2	105.0	75.6	51.4
6BAR		K12							56.8	30.4	79.4	53.0	101.9	75.5	124.5	98.1	82.5	56.0
7BAR	GK160SR	K5	51.0	33.4	67.5	49.9	100.6	83.0									49.2	31.6
7BAR		K6	44.7	23.5	61.1	40.0	94.2	73.2	127.3	106.2							59.1	38.0
7BAR		K7	38.4	13.7	54.9	30.3	87.9	63.4	121.0	96.4							68.9	44.3
7BAR		K8			48.5	20.4	81.6	53.5	114.7	86.5	147.7	119.6	180.8	152.7			78.7	50.6
7BAR		K9					75.3	43.7	108.4	76.8	141.5	109.8	174.5	142.9			88.6	56.9
7BAR		K10					68.9	33.4	102.0	66.5	135.1	99.6	168.2	132.6	201.2	165.7	98.4	63.3
7BAR		K11							95.7	57.0	128.7	90.1	161.8	123.1	194.8	156.2	108.3	69.6
7BAR		K12							89.4	47.5	122.5	80.6	155.5	113.6	188.6	146.7	118.1	75.9
8BAR	GK255SR	K5	73	47	98	72	148	122									79	52
8BAR		K6	63	31	88	56	138	107	188	157							94	63
8BAR		K7	52	15	77	40	127	90	178	141							110	73
8BAR		K8			67	25	117	75	167	125	217	176	268	226			125	84
8BAR		K9					107	59	157	109	207	159	257	210			141	94
8BAR		K10					96	44	146	94	196	144	247	194	297	245	157	105
8BAR		K11							136	78	186	128	236	178	286	228	173	115
8BAR		K12							125	63	176	113	226	163	276	213	188	125
8BAR	GK435SR	K5	128	85	171	127	256	213									129	86
8BAR		K6	111	59	154	102	239	187	325	273							155	103
8BAR		K7	94	33	137	76	222	162	308	247							181	120
8BAR		K8			120	50	205	136	291	221	376	307	462	392			206	137
8BAR		K9					187	110	273	196	358	281	444	367			232	155
8BAR		K10					170	84	256	169	341	255	427	340	512	426	258	172
8BAR		K11							238	143	324	229	409	314	495	400	284	189
8BAR		K12							221	118	307	203	392	289	478	374	310	206

Unit: Nm

Air pressure		Output torque of air to springs																Springs' output	
		2.5Bar		3Bar		4Bar		5Bar		6Bar		7Bar		8Bar					
Model	Spring Qty.	0° Start	90° End	0° Start	90° End	0° Start	90° End	0° Start	90° End	0° Start	90° End	0° Start	90° End	0° Start	90° End	0° Start	90° End		
GK665SR	K5	193	124	259	191	392	324									208	140		
	K6	165	83	232	149	365	282	498	415							250	168		
	K7	137	41	203	107	336	240	469	373							292	196		
	K8			176	66	309	199	442	237	575	465	708	598			333	223		
	K9					280	157	413	290	546	423	679	556			375	251		
	K10					253	115	386	248	519	381	652	514	785	647	417	279		
	K11							358	207	491	340	624	473	757	606	458	307		
	K12							330	165	463	298	596	431	729	564	500	335		
	GK1000SR	K5	332	222	438	329	651	542									309	200	
		K6	292	161	398	267	611	480	824	693							371	240	
		K7	252	99	358	205	571	418	784	631							433	280	
		K8			318	143	531	356	744	569	957	782	1169	995			495	320	
K9						491	295	704	507	917	720	1130	933			557	360		
K10						451	233	664	446	877	658	1090	871	1302	1084	618	400		
K11								624	384	837	597	1050	809	1263	1022	680	440		
K12								584	322	797	535	1010	748	1223	960	742	480		
GK1200SR		K5	390	285	523	418	789	684									380	275	
		K6	335	209	468	342	734	608	1000	874							456	330	
		K7	280	133	413	266	679	532	945	798							532	385	
		K8			358	190	624	456	890	722	1156	988	1422	1254			608	440	
	K9					569	380	835	646	1101	912	1367	1178			684	495		
	K10					514	304	780	570	1046	836	1312	1102	1578	1368	760	550		
	K11							725	494	991	760	1257	1026	1523	1292	836	605		
	K12							670	418	936	684	1202	950	1468	1216	912	660		
	GK1800SR	K5	552	409	744	600	1129	985									554	410	
		K6	470	297	662	489	1047	874	1432	1259							665	492	
		K7	388	187	580	379	964	764	1349	1149							775	575	
		K8			498	268	883	653	1267	1037	1652	1422	2037	1807			886	656	
K9						800	542	1185	926	1569	1311	1954	1696			998	739		
K10						718	431	1103	816	1488	1201	1872	1586	2257	1970	1108	821		
K11								1021	705	1406	1090	1791	1474	2176	1859	1219	903		
K12								939	594	1323	979	1708	1363	2093	1748	1330	985		
GK2700SR		K5	903	675	1195	968	1779	1552									787	560	
		K6	790	519	1083	811	1667	1396	2252	1981							943	672	
		K7	679	361	972	654	1556	1238	2141	1823							1101	783	
		K8			860	497	1444	1081	2029	1666	2614	2252	3199	2836			1258	895	
	K9					1332	923	1917	1509	2502	2094	3087	2678			1416	1007		
	K10					1220	767	1805	1352	2390	1937	2974	2521	3560	3107	1572	1119		
	K11							1693	1194	2278	1779	2862	2364	3448	2949	1730	1231		
	K12							1582	1037	2167	1623	2751	2207	3336	2792	1887	1342		
	GK3800SR	K5	1097	729													1061	730	
		K6	935	494	1316	875											1273	876	
		K7	772	258	1153	639	1916	1402									1485	1022	
		K8			991	403	1754	1166	2517	1929							1697	1168	
K9						1592	930	2355	1693	3118	2456					1909	1314		
K10						1430	695	2193	1458	2956	2221	3719	2984	4482	3747	2122	1460		
K11								2030	1222	2793	1985	3556	2748	4319	3511	2334	1606		
K12								1868	986	2631	1749	3394	2512	4157	3275	2546	1752		
GK5700SR		K5	1553	964													1702	1173	
		K6	1292	586	1863	1157											2043	1408	
		K7	1031	208	1602	779	2745	1922									2383	1642	
		K8			1341	401	2484	1544	3626	2686							2724	1877	
	K9					2224	1165	3336	2307	4508	3449					3064	2112		
	K10					1963	787	3105	1929	4247	3071	5390	4214	6532	5356	3405	2346		
	K11							2844	1551	3986	2693	5129	3836	6271	4978	3745	2581		
	K12							2584	1172	3726	2314	4869	3457	6011	4599	4086	2816		
	GK8000SR	K7	2028	869													2880	1837	
		K8	1736	411	2550	1225											3292	2100	
		K9			2259	768	3887	2396									3703	2362	
		K10			1967	311	3595	1939	5223	3567							4115	2624	
K11						3303	1482	4931	3110	6559	4738					4526	2887		
K12						3012	1025	4640	2653	6268	4281	7895	5908	9523	7536	4938	3149		
K13								4348	2195	5976	3823	7603	5450	9231	7078	5349	3412		
K14								4057	1738	5685	3366	7312	4993	8940	6621	5761	3674		
K15								3765	1281	5393	2909	7020	4536	8648	6164	6172	3937		
K16										5101	2452	6728	4079	8356	5707	6584	4199		

Dimension of GK007DA

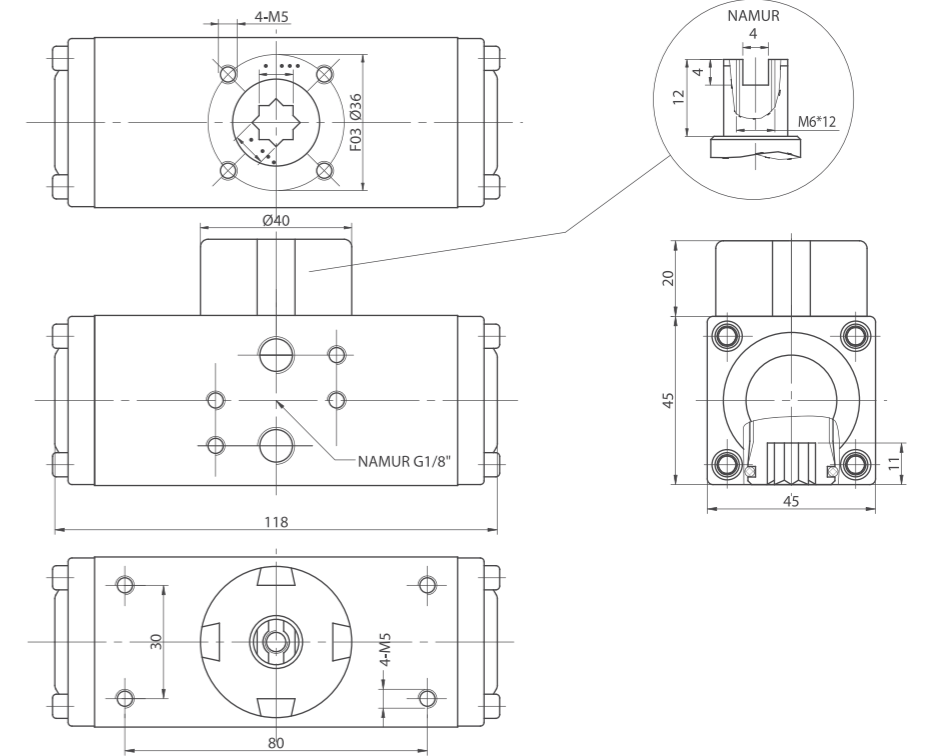

Dimension of GK012DA

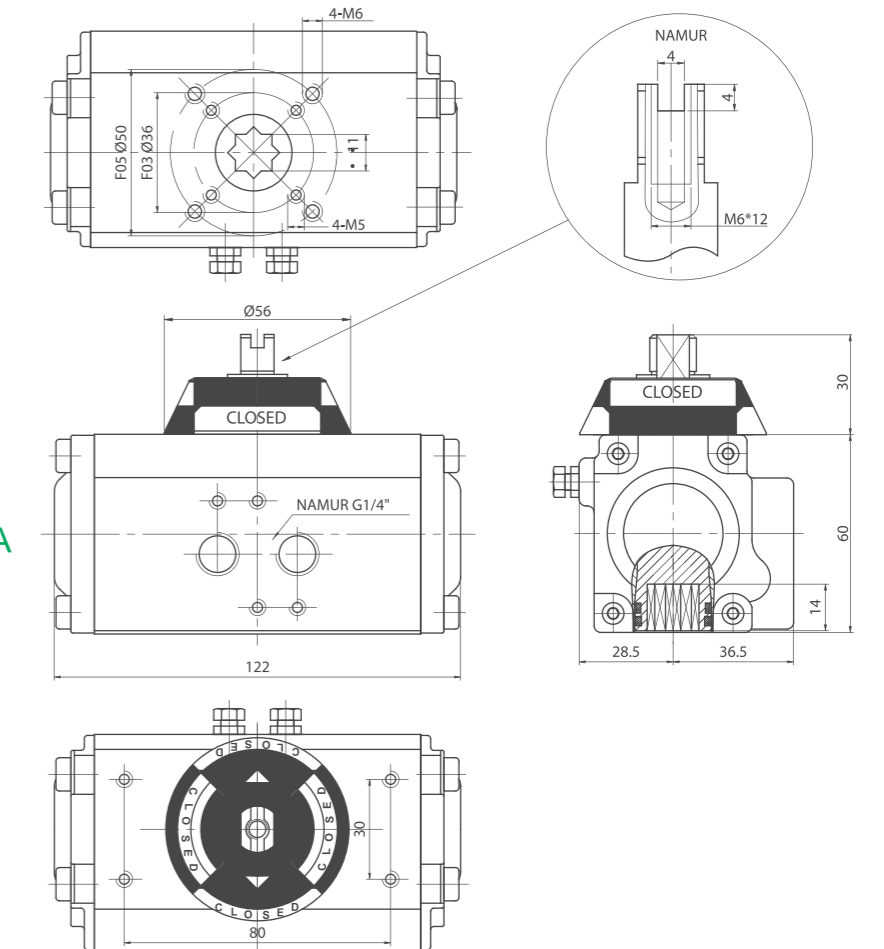

Dimension of GK020DA~GK2700DA

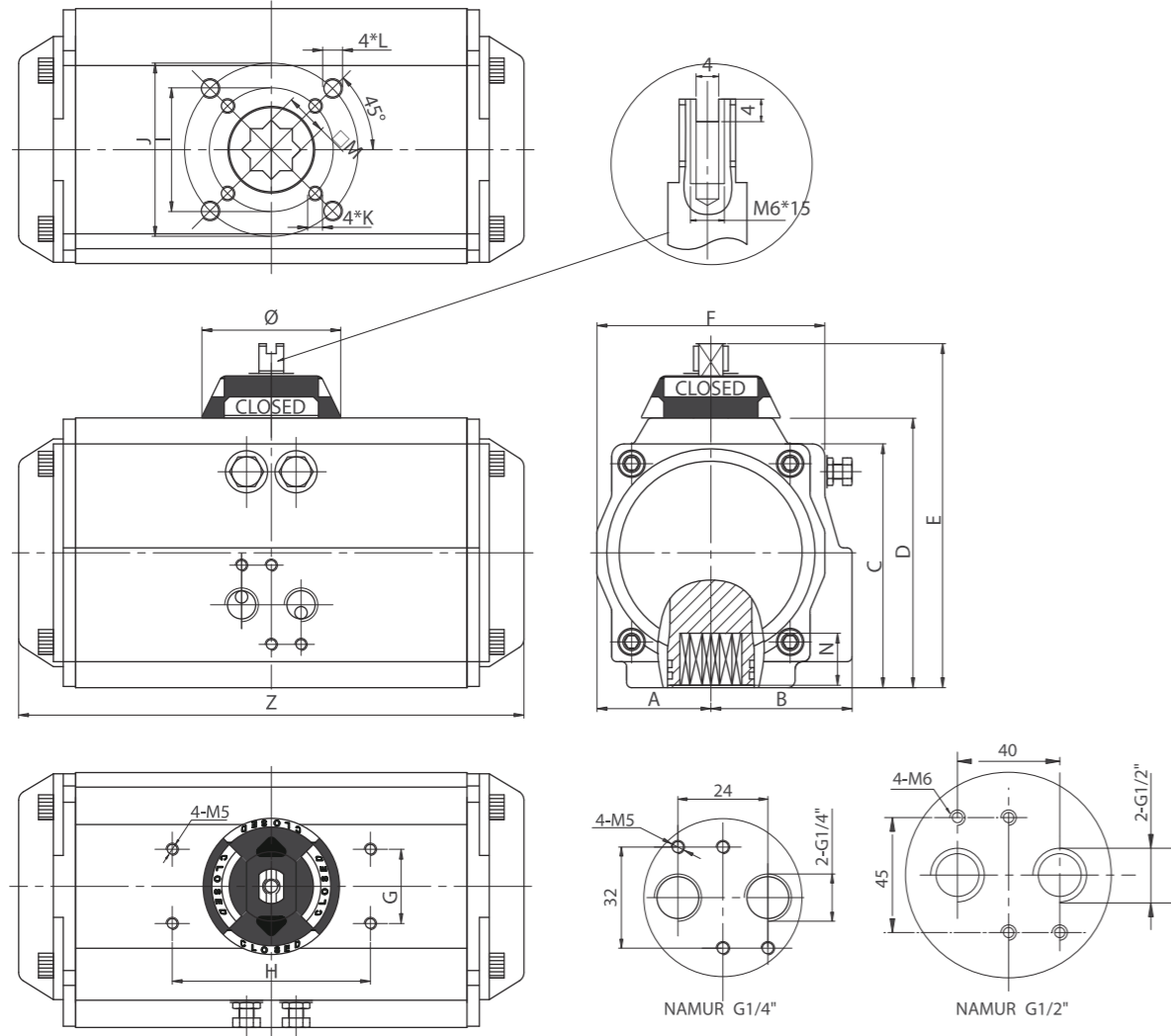

Unit: mm

Model	A	B	C	D	E	F	G	H	I	J	K	L	M	N	Z	Ø	Air Connection
GK020	30	41.5	65.5	72	102	65	30	80	Ø36	Ø50	M5x8	M6x10	11	14	147	Ø56	NAMUR G1/4"
GK035	36	47	81	87.5	117.5	72	30	80	Ø50	Ø70	M6x10	M8x13	14	18	168	Ø56	NAMUR G1/4"
GK050	42	53	94	99.5	129.5	81	30	80	Ø50	Ø70	M6x10	M8x13	14	18	184	Ø56	NAMUR G1/4"
GK075	46	57	98.5	108.7	138.7	92	30	80	Ø50	Ø70	M6x10	M8x13	17	21	204	Ø56	NAMUR G1/4"
GK110	50	58.5	111	116.5	146.5	98	30	80	Ø50	Ø70	M6x10	M8x13	17	21	262	Ø56	NAMUR G1/4"
GK160	57.5	64	122.5	133	163	109.5	30	80	Ø70	Ø102	M8x13	M10x16	22	26	268	Ø56	NAMUR G1/4"
GK255	67.5	74.5	145.5	155	185	127.5	30	80	Ø70	Ø102	M8x13	M10x16	22	26	301	Ø68	NAMUR G1/4"
GK435	75	77	161	172	202	137.5	30	80	Ø102	Ø125	M10x16	M12x20	27	31	390	Ø68	NAMUR G1/4"
GK665	87	87	184	197	227	158	30	80	Ø102	Ø125	M10x16	M12x20	27	31	458	Ø68	NAMUR G1/4"
GK1000	103	103	213	230	260	189	30	130		Ø140		M16x25	36	40	525	Ø91	NAMUR G1/4"
GK1200	113	113	235.5	255	285	210	30	130		Ø140		M16x25	36	40	532	Ø91	NAMUR G1/4"
GK1800	130	130	264.5	289	319	245	30	130		Ø165		M20x25	46	50	602	Ø91	NAMUR G1/4"
GK2700	147	147	299	326	356	273	30	130		Ø165		M20x25	46	50	722	Ø91	NAMUR G1/2"

Dimension of GK3800DA~GK8000DA

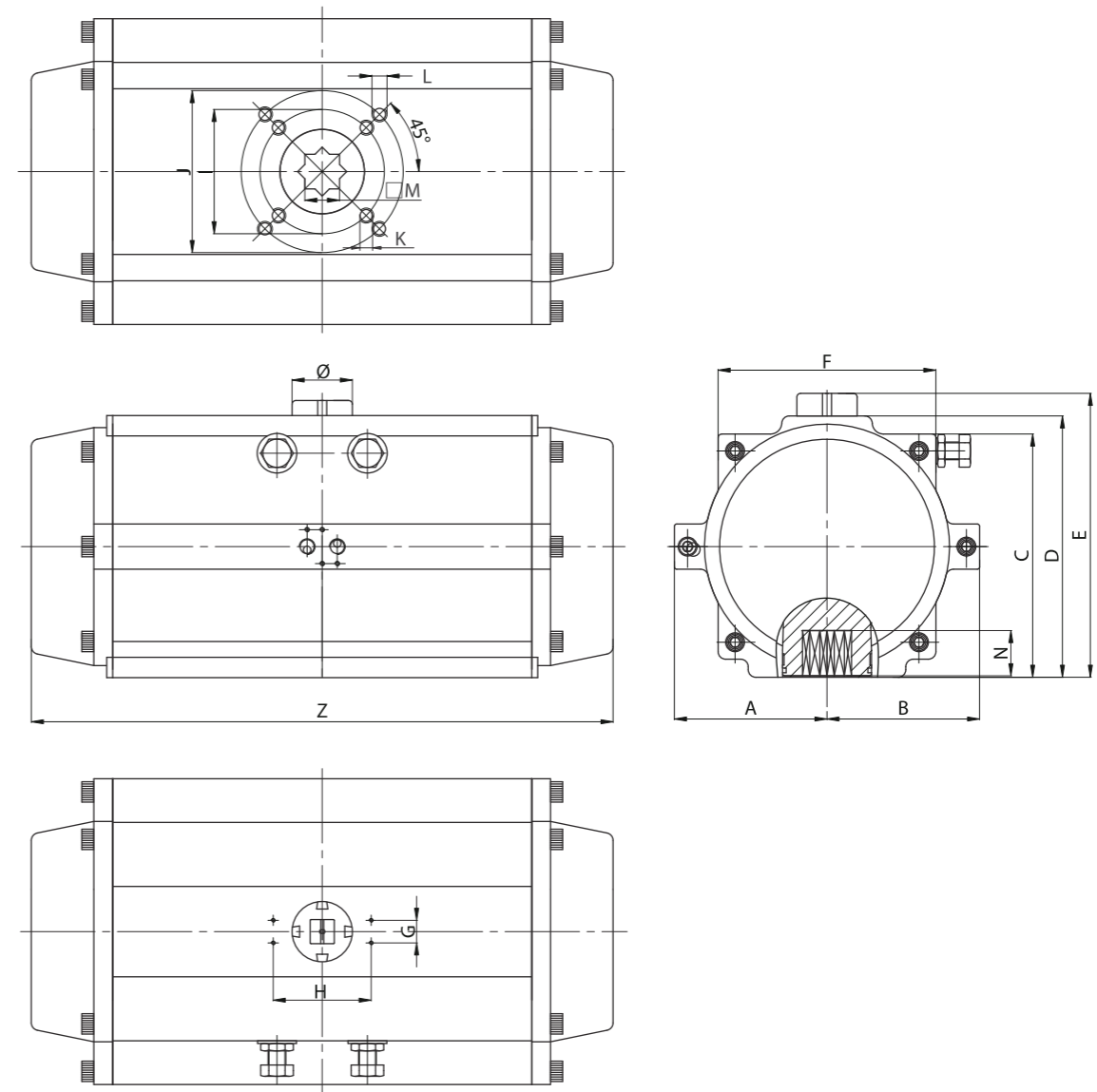

Unit: mm

Model	A	B	C	D	E	F	G	H	I	J	K	L	M	N	Z	Ø	Air Connection
GK3800	203	203	324	348	378	290	30	130	Ø165	Ø215	4-M20x25	4-M20x25	46	60	772	Ø80	NAMUR G1/2"
GK5700	230	230	380	410	440	336	30	130	Ø165	Ø215	4-M20x25	4-M20x25	46	60	870	Ø80	NAMUR G1/2"
GK8000	258	258	450	480	510	360	30	130	Ø165	Ø254	4-M20x25	8-M16x25	55	60	930	Ø80	NAMUR G1/2"

Cylinder

Unit: mm

Model	GK007	GK012	GK020	GK035	GK050	GK075	GK110	GK160	GK255
Cylinder	Ø32	Ø40	Ø52	Ø63	Ø75	Ø83	Ø92	Ø105	Ø125

Model	GK435	GK665	GK1000	GK1200	GK1800	GK2700	GK3800	GK5700	GK8000
Cylinder	Ø140	Ø160	Ø190	Ø210	Ø240	Ø270	Ø300	Ø350	Ø400

120°, 135°, 180° Double Acting and Spring Return

120°, 135°, 180° actuators provide rotations of 120°, 135° or 180°. The external travel stop is available as a standard in fully open position (120°, 135° or 180°) and in fully close position (0°), and it is easily and precisely adjustable of +/- 5° in both directions.

Output Torque

Output torque of double acting actuators please refer to the torque of 90° actuators.

Dimension

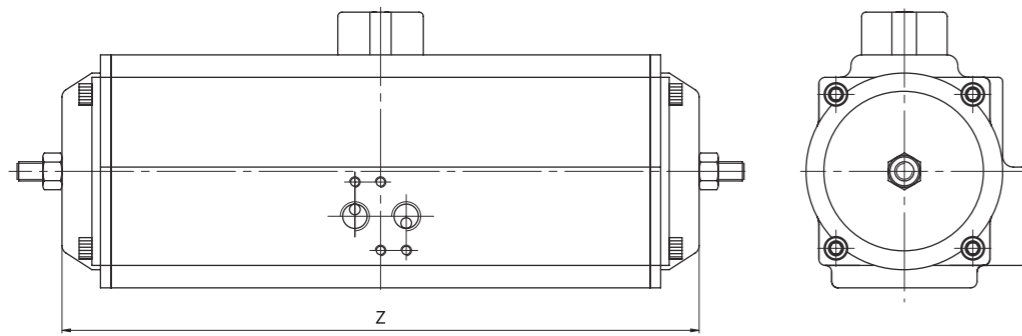

Size	GK020	GK050	GK075	GK110	GK160	GK255	GK435	GK665	GK1000	GK1200	GK1800	GK2700
Z(mm)	330	376	378	432	520	594	733	840	1034	1034	1027	1170

If you enquire any further information of spring return actuators, please do not hesitate to contact us.

Three Position Pneumatic Actuator

GEKO 3 position pneumatic actuators provide an operation of 0° 45° - 90°. The intermediate position is achieved by an external mechanical stop of movement on the 2 auxiliary pistons. This intermediate stop position is adjustable from 0-90, for example 5°, 20°, 30°, 50°, 75° etc. The intermediate position is easily achieved by adjusting the external nuts located outside the two end-caps.

Both type, double acting and spring return, are available.

The 0°-90°-180° acting actuator is available.

Output Torque

Output torque of double acting and spring return actuators please refer to the torque of 90° actuators.

Dimension of double acting actuator

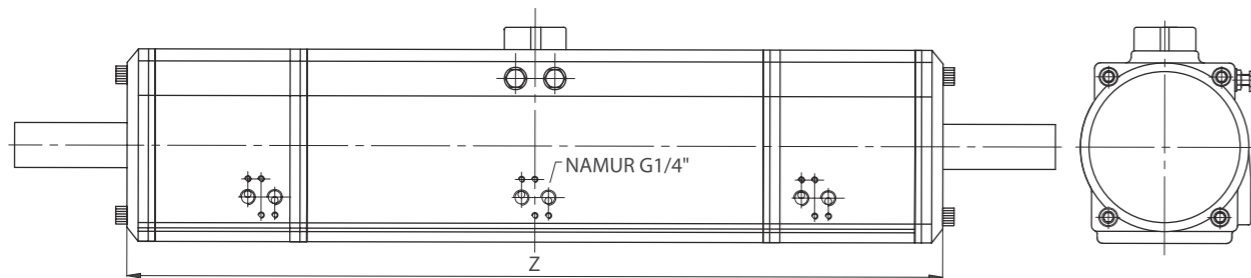

Size	GK020-3P	GK050-3P	GK075-3P	GK110-3P	GK160-3P	GK255-3P	GK435-3P	GK665-3P	GK1000-3P	GK1200-3P	GK1800-3P	GK2700-3P
Z(mm)	266	301	304	338	410	466	558	646	806	806	886	1000

If you enquire any further information of spring return actuators, please do not hesitate to contact us.

In order to control the operation of GEKO 3-position pneumatic actuators a system of solenoid valves controlling a sequence of air supplies to the actuator is required as described below:

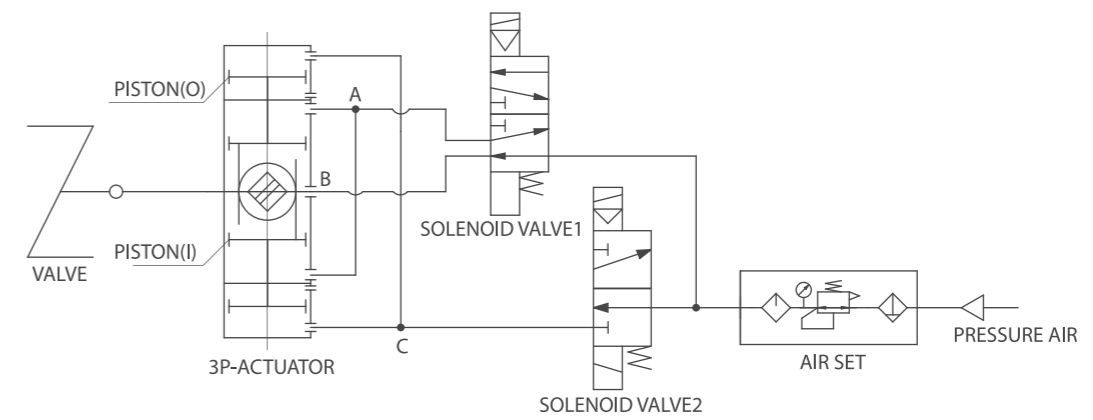

	0°	90°	30°	0°
SOLENOID VALVE1	OFF	ON	OFF	OFF
SOLENOID VALVE2	OFF	OFF	ON	OFF

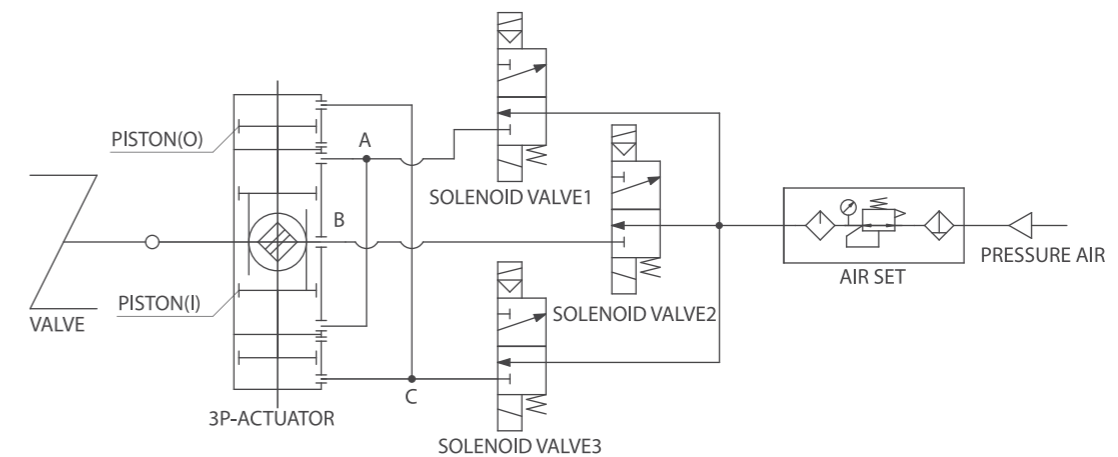

	0°	30°	90°	30°	0°
SOLENOID VALVE1	OFF	OFF	ON	OFF	OFF
SOLENOID VALVE2	ON	OFF	OFF	ON	ON
SOLENOID VALVE3	OFF	ON	ON	ON	OFF

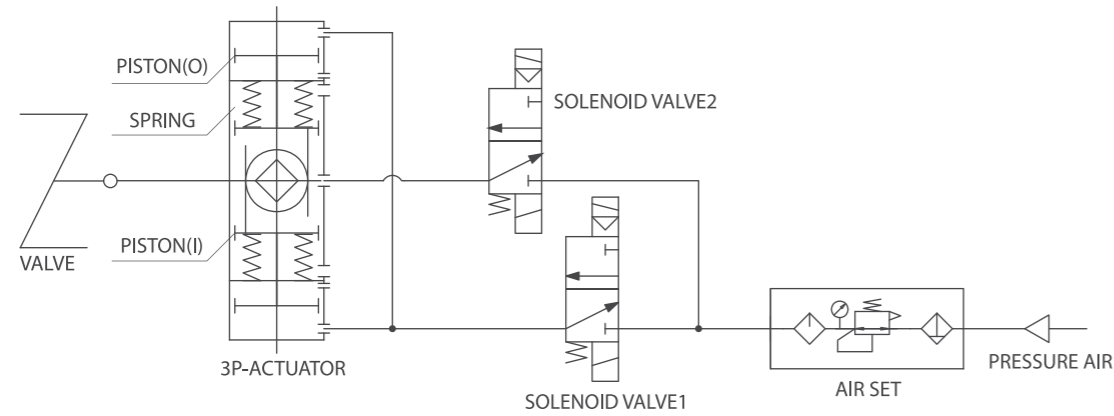

	0°	30°	90°	30°	0°
SOLENOID VALVE1	OFF	ON	OFF	ON	OFF
SOLENOID VALVE2	OFF	ON	ON	ON	OFF



Stainless Steel Rack and Pinion Actuator



GEKO has developed a new line of stainless steel actuators. This new line of stainless steel actuators has been designed to be corrosive environment by using forged high quality stainless steel body material in SS304, SS316, SS316L.

Appropriate Field of Applications:

- Food Industry
- Sanitary
- Enology
- Corrosive Enviroments
- Pharmaceutical
- Cosmetics
- Marine and Offshore Plant

These actuators are manufactured in Double Acting and Spring Return.

The stainless steel actuators are also available with optional polished surface, particularly for Sanitary and Pharmaceutical applications.



Features and Benifits:

The new line of stainless steel actuators offers a lot innovative design features and benefits like:

- High performance
- Full compliance with latest worldwide
- Simply, compact and moderm shape to avoid cavity and corrosive deposit build up
- Namur air connection interface, for easy mounting of solenoid valves
- Namur mounting dimension on top, for simply ancilliary installation
- Full conformance to the latest specifications: ISO 5211 and DIN 3337
- Dual piston rack and pinion design for compact construction, symmetric mounting position, high-cycle life and fast operation, reverse rotation can be accomplished in the field by simply inverting the pistons
- Preloaded coating springs are made from the high quality material for resistant to corrosion and longer service life, which can be demounted safely and conveniently to satisfy different requirements of torque by changing quantity of springs.

Assemble, Parts and Materials

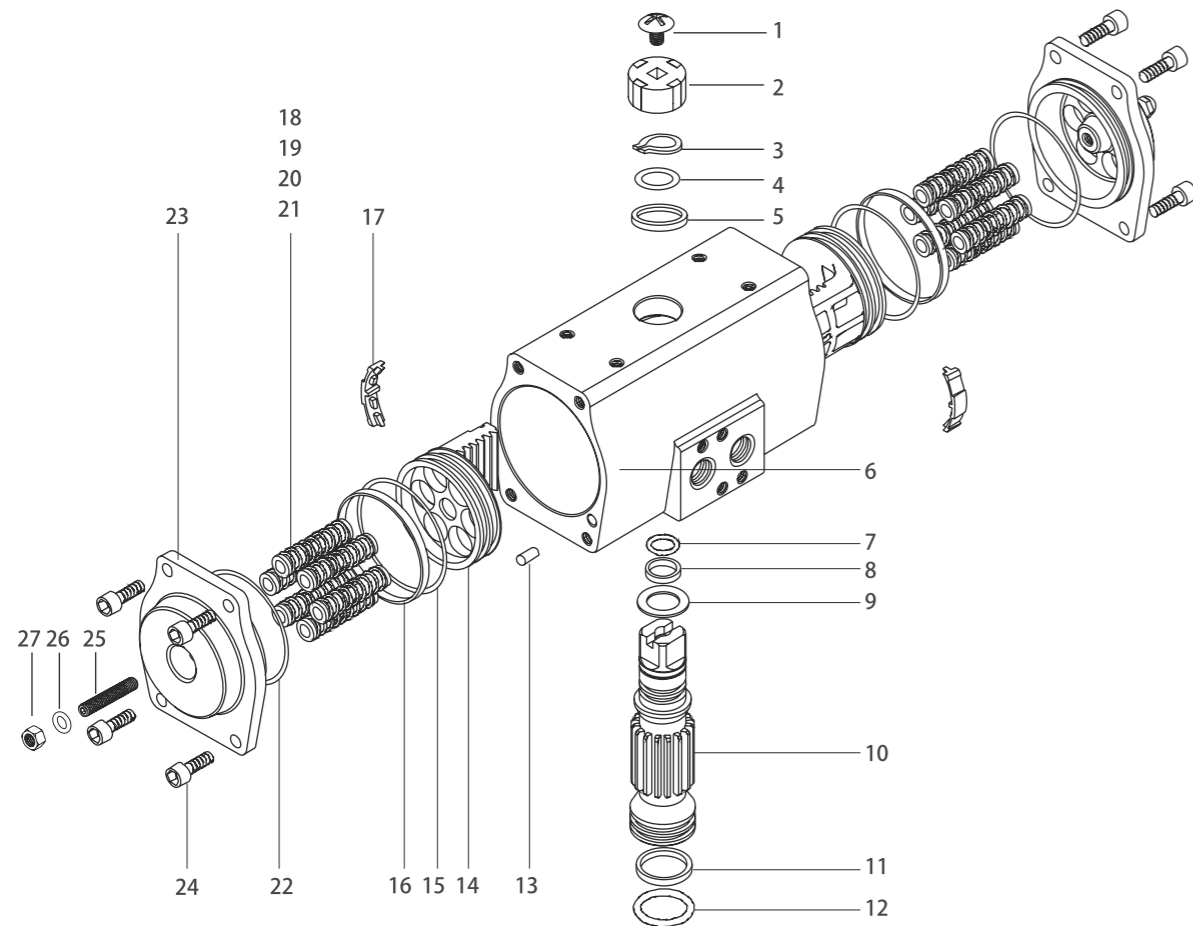

No.	Description	Qty.	Standards Material	No.	Description	Qty.	Standards Material
1	Indicator screw	1	Plastic(ABS)	15	O-ring(Piston)	2	Viton/NBR
2	Indicator	1	Plastic(ABS)	16	Bearing(Piston)	2	Polyoxymethylene
3	Circlip	1	Stainless steel(304)	17	Guide(Piston)	2	Nylon6
4	Thrust washer	1	Stainless steel(304)	18	Spring	*	Spring steel
5	Outside washer	1	Polyoxymethylene	19	Spring Retainer(L)	*	Nylon66
6	Body	1	Stainless steel(304)	20	Spring Retainer(R)	*	Nylon66
7	O-ring(Pinion top)	1	Viton/NBRNBR	21	Retainer Connector	*	Brass
8	Bearing(Pinion top)	1	Polyoxymethylene	22	O-ring(End-Cap)	2	Viton/NBR
9	Inside washer	1	Polyoxymethylene	23	End-Cap	2	Stainless steel(304)
10	Pinion	1	Stainless steel(304)	24	End-Cap Screw	8	Stainless steel(304)
11	Bearing(Pinion bottom)	1	Polyoxymethylene	25	Adjust Screw	2	Stainless steel(304)
12	O-ring(Pinion bottom)	1	Viton/NBR	26	O-ring(Adjust Screw)	2	Stainless steel(304)
13	Plug	2	NBR	27	Nut(Adjust Screw)	2	Viton/NBR)
14	Piston	2	Stainless steel(304)				

SS Series Actuator Dimension Table

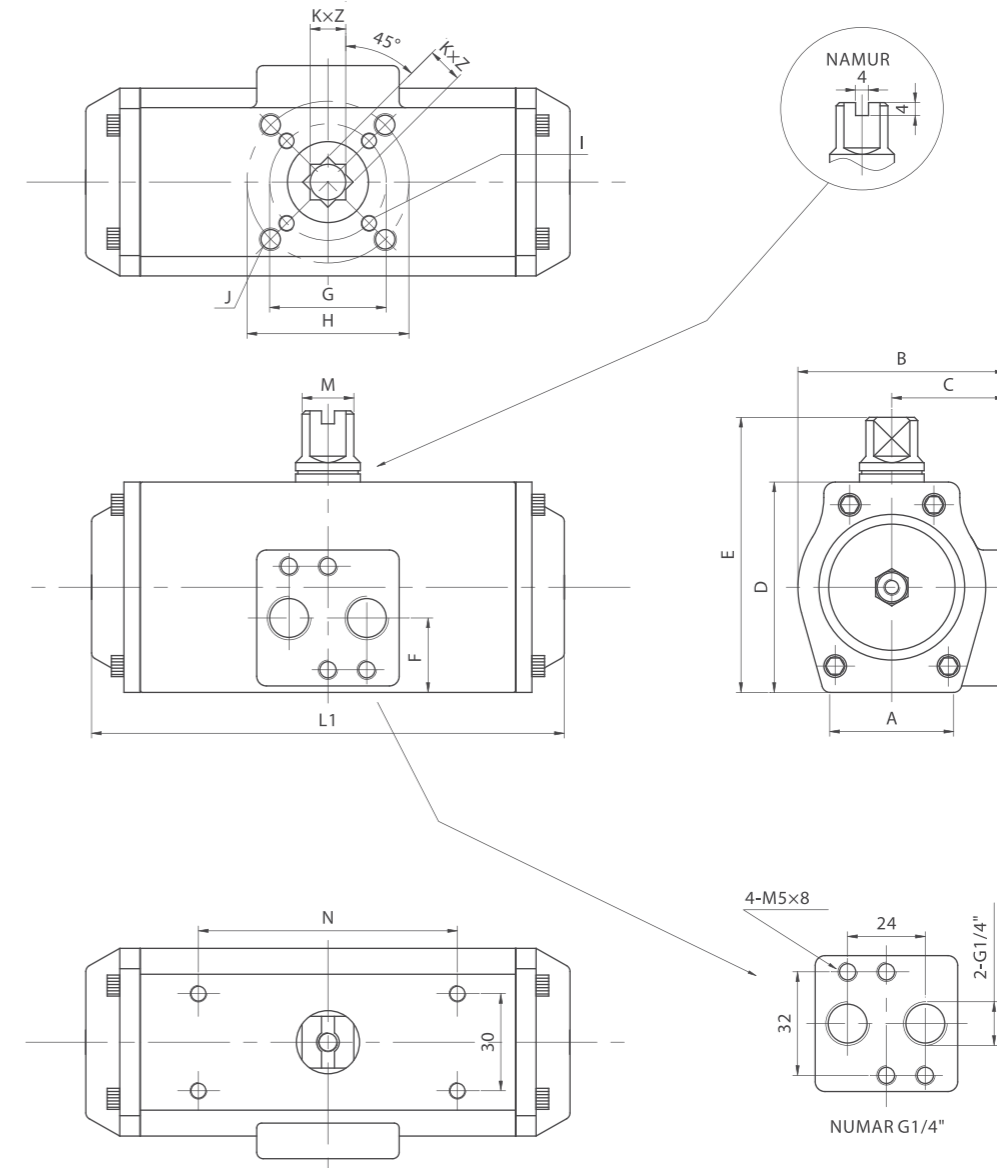

Unit: mm

Model	A	B	C	D	E	F	G	H	I	J	K	L1	M	N	Z	Air Connection
GK015	48	70	41	65	85	23	Ø36	Ø50	M5x8	M6x10	11	148	16	80	14	NAMUR G1/4"
GK035	58	78	43	81	101	23		Ø50		M6x10	14	167	16	80	18	NAMUR G1/4"
GK075	75	102	53.5	108	128	24	Ø50	Ø70	M6x10	M8x13	17	197	16	80	21	NAMUR G1/4"
GK160	92	122	63.5	133	153	24		Ø70		M8x13	22	251	16	80	26	NAMUR G1/4"
GK255	96	140	72	155	185	28	Ø70	Ø102	M8x13	M10x16	22	284	22	130	26	NAMUR G1/4"
GK435	112	154	78	171.5	201.5	34	Ø102	Ø125	M10x16	M12x20	27	360	22	130	31	NAMUR G1/4"
GK665	127	173	86	197	227	39	Ø102	Ø125	M10x16	M12x20	27	420	22	130	31	NAMUR G1/4"
GK1200	135	225	115	250	280	42		Ø140		M16x25	36	530	32	130	40	NAMUR G1/4"

Output Torque of Double Acting Actuators

Unit: Nm

Model	Air Supply (Bar)											
	2		2.5		3		4		4.5		5	
	Start	End	Start	End	Start	End	Start	End	Start	End	Start	End
GK015DA	6.0	7.6	9.1	12.1	13.6	15.1	16.6	18.1	21.1	24.2		
GK035DA	14.2	17.8	21.3	28.4	32.0	35.5	39.1	42.6	49.7	56.8		
GK075DA	30.8	38.5	46.2	61.6	69.4	77.1	84.8	92.5	107.9	123.3		
GK160DA	65.8	82.2	98.7	131.6	148.0	164.4	180.9	197.3	230.2	263.1		
GK255DA	103	128	154	205	231	256	282	308	359	410		
GK435DA	175	219	263	351	395	439	482	526	614	702		
GK665DA	267	334	401	535	601	668	735	802	935	1069		
GK1200DA	526	658	789	1052	1184	1316	1447	1579	1842	2105		

Output Torque of Spring Return Actuators

Unit: Nm

Model	Spring Qty.	Air pressure(Bar)																Springs'output		
		2		2.5		3		4		5		6		7		8		90°	0°	
		0°	90°	0°	90°	0°	90°	0°	90°	0°	90°	0°	90°	0°	90°	0°	90°			
		Start	End	Start	End	Start	End	Start	End	Start	End	Start	End	Start	End	Start	End	Start	End	
GK015SR	5	3.0	1.2	4.6	2.8													4.6	2.9	
	6	2.3	0.2	3.9	1.8	5.4	3.3											5.5	3.5	
	7			3.3	0.8	4.8	2.3	7.8	5.3									6.5	4.1	
	8					4.2	1.3	7.2	4.3	10.2	7.3							7.4	4.6	
	9							6.6	3.4	9.6	6.4	12.6	9.4					8.3	5.2	
	10							6.0	2.4	9.0	5.4	12.0	8.4	15.0	11.4	18.1	14.5	9.2	5.8	
	11									8.4	4.4	11.4	7.4	14.4	10.4	17.5	13.5	10.1	6.4	
	12									7.8	3.5	10.8	6.5	13.8	9.5	16.9	12.6	11.1	7.0	
	GK035SR	5	7.0	3.2	10.6	6.8													10.4	6.8
		6	5.6	1.0	9.2	4.6	12.7	8.1											12.5	8.2
		7			7.7	2.4	11.2	5.9	18.3	13.0									14.6	9.6
		8					9.8	3.7	16.9	10.8	24.0	17.9							16.7	10.9
9								15.4	8.6	22.5	15.7	29.6	22.8					18.8	12.3	
10								14.0	6.4	21.1	13.5	28.2	20.6	35.3	27.7	42.4	34.8	20.9	13.7	
11										19.7	11.3	26.8	18.4	33.9	25.5	41.0	32.6	22.9	15.0	
12										18.2	9.1	25.3	16.2	32.4	23.3	39.5	30.4	25.0	16.4	
GK075SR		5	14.2	6.6	21.9	14.3													23.0	15.8
		6	10.8	1.7	18.5	9.4	26.2	17.1											27.6	19.0
		7			15.2	4.6	22.9	12.3	38.3	27.7									32.2	22.1
		8					19.6	7.4	35.0	22.8	50.5	38.3							36.8	25.3
	9							31.6	18.0	47.1	33.5	62.5	48.9					41.4	28.5	
	10							28.3	13.2	43.8	28.7	59.2	44.1	74.6	59.5	90.0	74.9	46.0	31.6	
	11									40.5	23.8	55.9	39.2	71.3	54.6	86.7	70.0	50.6	34.8	
	12									37.1	19.0	52.5	34.4	67.9	49.8	83.3	65.2	55.2	38.0	
	GK160SR	5	32.5	14.0	48.9	30.4													49.2	31.6
		6	25.8	3.6	42.2	20.0	58.7	36.5											59.1	38.0
		7			35.6	9.7	52.1	26.2	85.0	59.1									68.9	44.3
		8					45.4	15.8	78.3	48.7	111.1	81.5							78.7	50.6
9								71.7	38.4	104.5	71.2	137.4	104.1					88.6	56.9	
10								65.0	28.0	97.8	60.8	130.7	93.7	163.6	126.6	196.5	159.5	98.4	63.3	
11										91.1	50.4	124.0	83.3	156.9	116.2	189.8	149.1	108.3	69.6	
12										84.5	40.1	117.4	73.0	150.3	105.9	183.2	138.8	118.1	75.9	

Model	Spring Qty.	Air pressure(Bar)																Springs'output		
		2		2.5		3		4		5		6		7		8		90°	0°	
		0°	90°	0°	90°	0°	90°	0°	90°	0°	90°	0°	90°	0°	90°	0°	90°			
		Start	End	Start	End	Start	End	Start	End	Start	End	Start	End	Start	End	Start	End	Start	End	
GK255SR	5	47.9	20.5	72.9	45.5													78.4	52.4	
	6	36.9	4.0	61.9	29.0	87.9	55.0											94.1	62.8	
	7			50.8	12.5	76.8	38.5	127.8	89.5									109.7	73.3	
	8					65.8	22.0	116.8	73.0	167.8	124.0							125.4	83.8	
	9							105.8	56.5	156.8	107.5	208.8	159.5					141.1	94.2	
	10							94.8	40.0	145.8	91.0	197.8	143.0	248.8	194.0	299.8	245.0	156.8	104.7	
	11									134.8	74.5	186.8	126.5	237.8	177.5	288.8	228.5	172.4	115.2	
	12									123.7	58.0	175.7	110.0	226.7	161.0	277.7	212.0	188.1	125.7	
	GK435SR	5	84.7	39.3	128.7	83.3													129.0	85.8
		6	66.6	12.1	110.6	56.1	154.6	100.1											154.8	102.9
		7			92.6	29.0	136.6	73.0	224.6	161.0									180.5	120.1
		8					118.5	45.8	206.5	133.8	294.5	221.8							206.3	137.3
9								188.5	106.7	276.5	194.7	363.5	281.7					232.1	154.4	
10								170.4	79.5	258.4	167.5	345.4	254.5	433.4	342.5	521.4	430.5	257.9	171.6	
11										240.3	140.4	327.3	227.4	415.3	315.4	503.3	403.4	283.7	188.7	
12										222.3	113.2	309.3	200.2	397.3	288.2	485.3	376.2	309.5	205.9	
GK665SR		5	120.0	47.7	187.0	114.7													208.3	139.7
		6	90.6	3.9	157.6	70.9	224.6	137.9											250	168
		7			128.2	27.0	195.2	94.0	329.2	228.0									292	196
		8					165.8	50.2	299.8	184.2	432.8	317.2							333	223
	9							270.4	140.3	403.4	273.3	537.4	407.3					375	251	
	10							241.0	96.4	374.0	229.5	508.0	363.5	641.0	496.5	775.0	630.5	417	279	
	11									344.6	185.6	478.6	319.6	611.6	452.6	745.6	586.6	458	307	
	12									315.2	141.7	449.2	275.7	582.2	408.7	716.2	542.7	500	335	
	GK1200SR	5	237	126	369	258													360	260
		6	179	46	311	178	442	309											432	313
		7			253	99	384	230	647	493									503	365
		8					326	150	589	413	853	677							575	417
9								531	333	795	597	1058	860					647	469	
10								473	253	737	517	1000	780	1263	1043	1526	1306	719	521	
11										679	437	942	700	1205	963	1468	1226	791	573	
12										621	357	884	620	1147	883	1410	1146	863	625	

How to Order

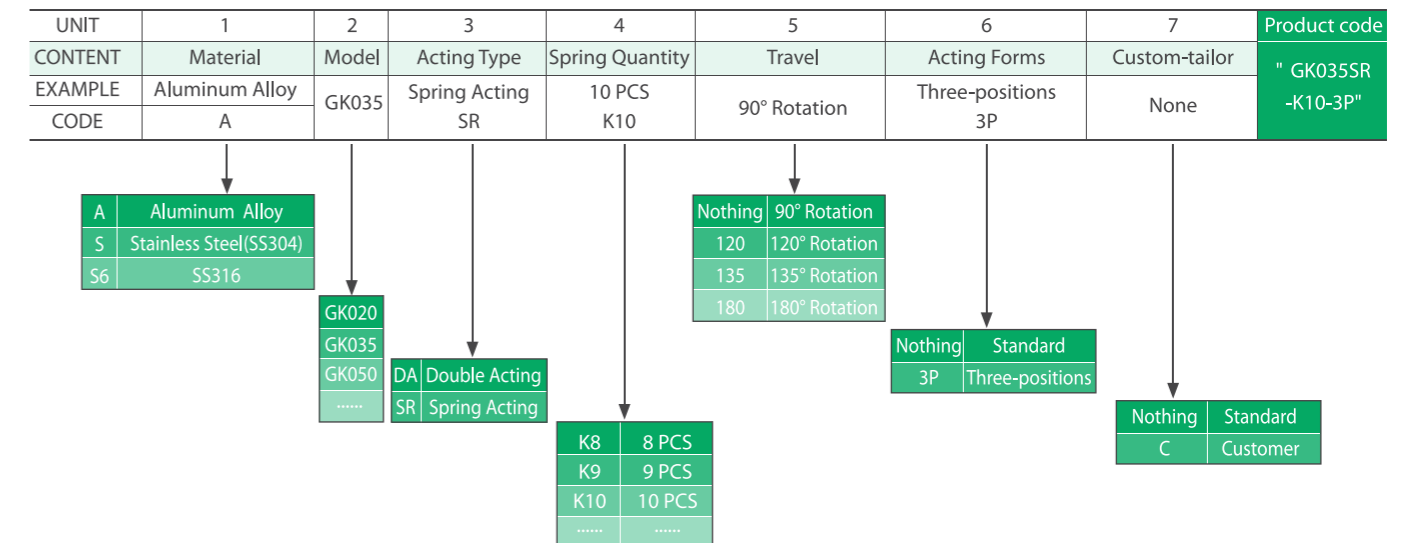

The valve bus position monitor



The valve bus position monitor is belonged to intelligentize and internet measurement and control field, which internally install with AS-I or DeviceNet (CPU) and HALL sensor. It's used for real-time online analysis in judging the position of valves, and it can connect the valve to internet by the AS-Interface contract agreement, which exchange information and communication. It can achieve the intelligentize recognition, location, track, monitor and manage by above all. The valve monitor is a new bus monitor machine, which can realize the position of valve by AS-I or DeviceNet bus agreement. It can transform the position of valve to the digital signal of hex system by the independent FCS system or DCS and FCS subsystem that is form with connecting two-core cable and web of things' host and PC. The intelligentize and internet monitor of valves are achieved by PC (PLC).

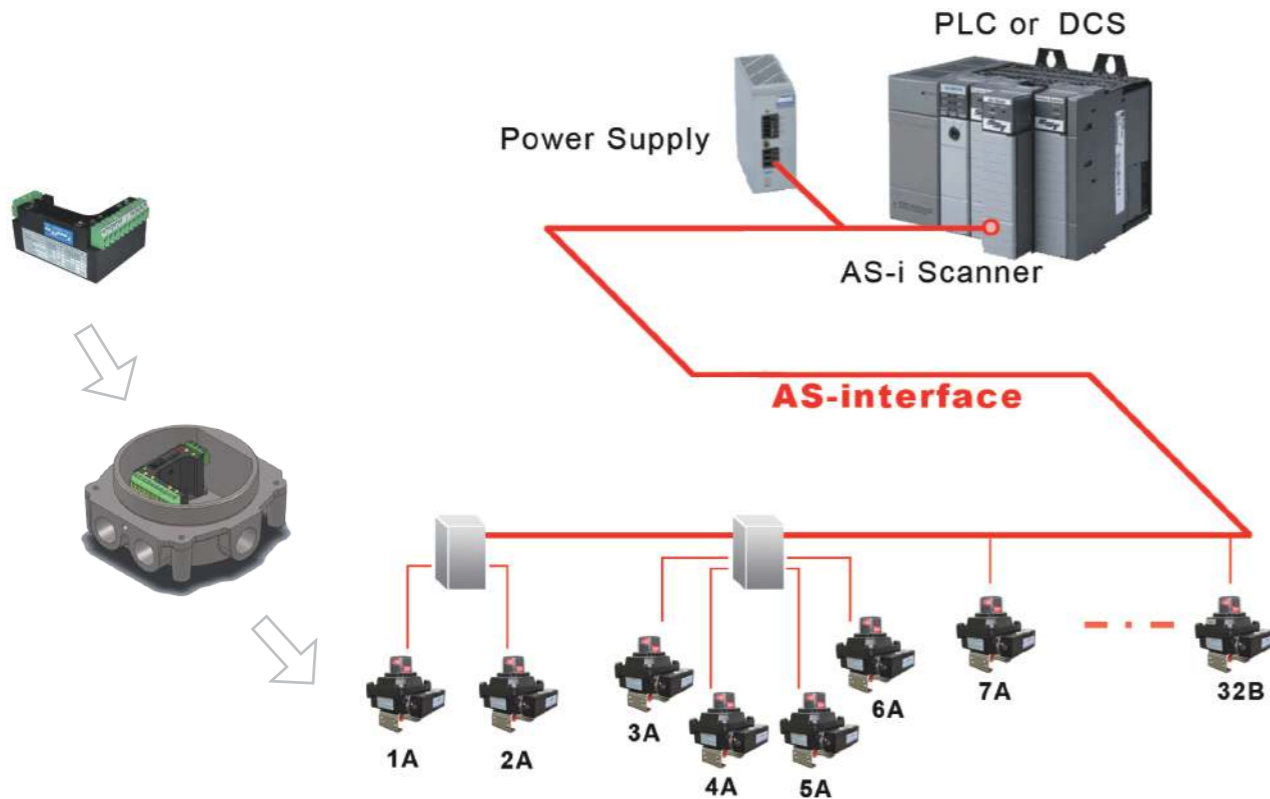

Additional switch options and technical issues, please consult the company.

The ALSD discrete type controller that has AS-Interface functional card mainly supports the product of mainstream PLC/DCS manufacturers. Its best feature is connecting directly the AS-I to the control system of client. Some card even support the independent two AS-I internet. The card can communicate with the A/B address module. Every card can control 62 module internets.

GEKO Solenoid

GKV 5/6 series 3/2 normal close or 5/2 uncoil and twin coil solenoid have anodic oxidation aluminum alloy body and stainless body. The gas port is G1/4" (or NPT) thread. Every solenoid takes with two 3/2 and 5/2 NAMUR standard installed connect plate, and it's used for controlling the single acting and double acting pneumatic actuator.

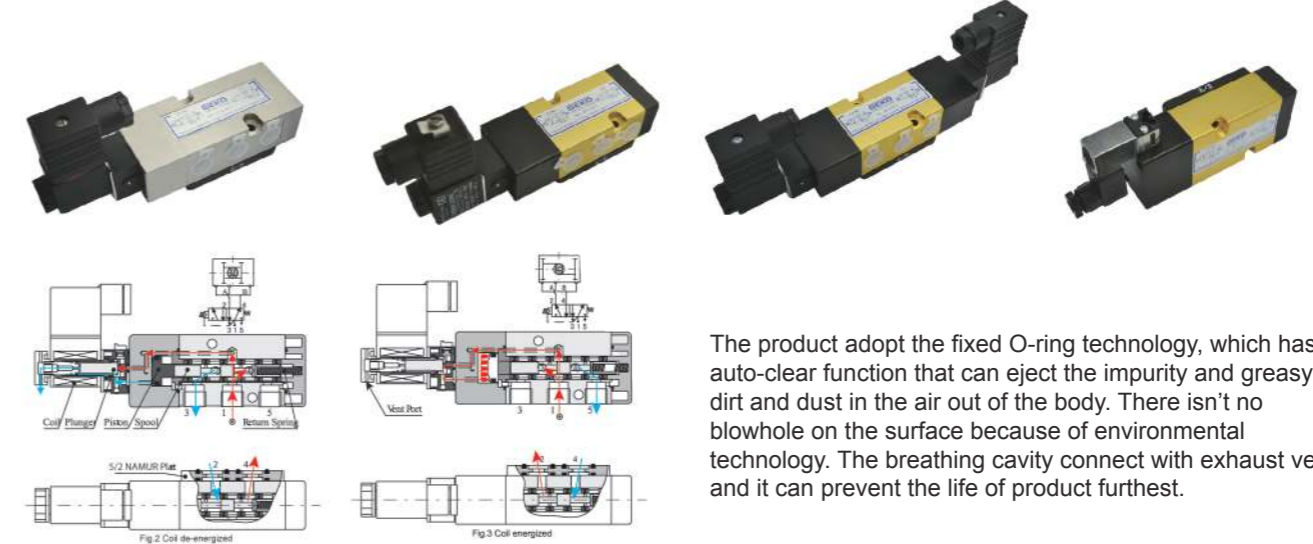

The product adopt the fixed O-ring technology, which has auto-clear function that can eject the impurity and greasy dirt and dust in the air out of the body. There isn't no blowhole on the surface because of environmental technology. The breathing cavity connect with exhaust vent, and it can prevent the life of product furthest.

選型表

GKV	5	10	F3	C0
GEKO Solenoid	10: Single electronic control 20: Double electronic control		2W3P/2W5P Exchange	C0: Normal coil C1: Low-power consumption coil C2: Exm IIBT4 C3: Exia IIBT6 C4: Exd II BT6 C5: Exd II CT6
	5: Aluminum body 6: Stainless steel body			

GKVM 231 micro solenoid:



- Feature:
- 3W2P normally close
 - Manual operation
 - 1/4 or 1/8 BSPP on NPT
 - Directly installed in the actuator
 - 40mm air filter
 - Cv=0.15

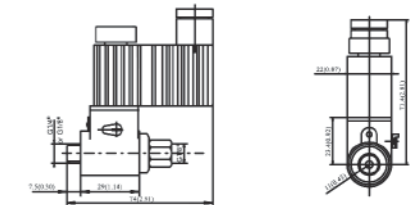
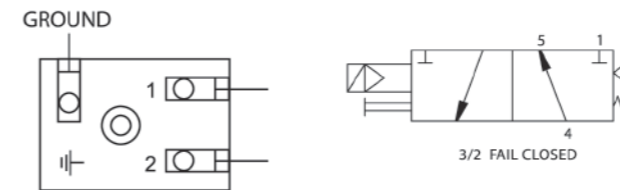

GKS-100 Protected Series Limit Switch

GKS-100 Protected Series Limit Switch offers tight, economy, stable product, many switches and high temperature and high pressure for visual position and distant signal.

Feature:

1. Two-dimension visual signal, high contrast color design, examine the position in all angle.
2. In accordance with NAMUR standard, promote interchangeability furthest.
3. Anti-proof bolt. It wouldn't drop when distuffing.
4. Temp:-25~80°C Enclosure Protection: IP67



Pre-wired for standard eight terminal blocks; many choices of terminal blocks

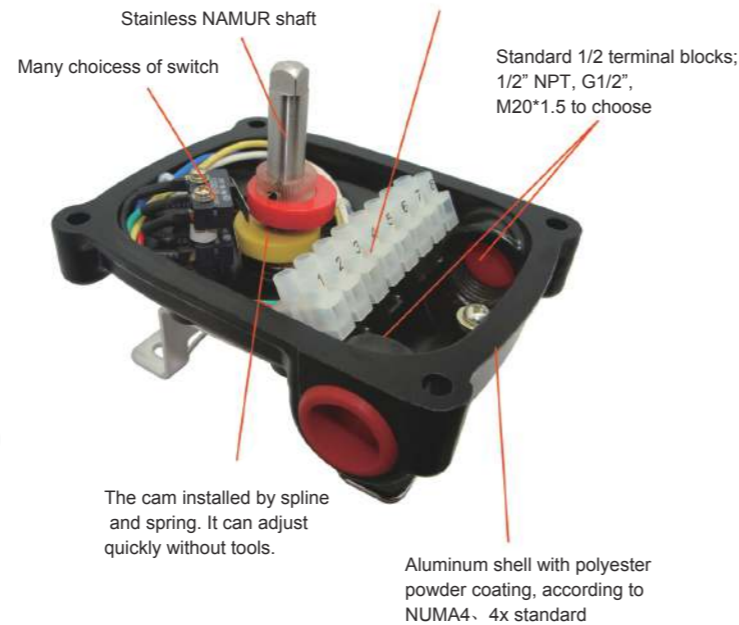
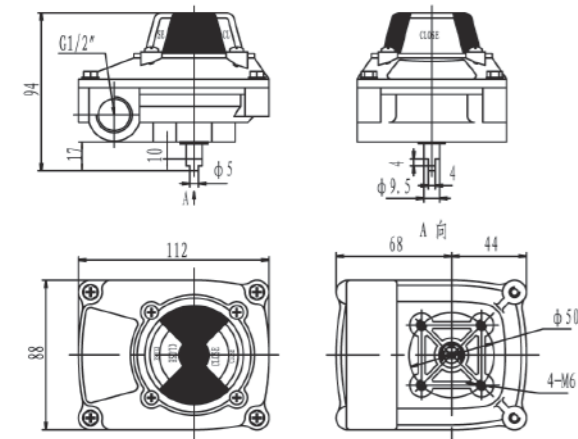

Selection Table

Optiona	Type	Switch	Wiring Port	External Wiring Position	Indicator	NAMUR Bracket (Carbon Steel)
-I prefix	GKS-100	Mechanical(Passive)	2-G1/2"	2External Wiring Position	1- Aluminium cap (high temperature 120°C)	MB1.0:30*80 H:20
-Double D Shaft	Achieved Approval	M2: 2SPDT	2-1/2"NPT	4External Wiring Position	2- Dome 90°indicator	MB1.0: 30*80 H:20
		M5: 2DPDT	2-M20*1.5	6External Wiring Position	3- Flat 90°indicator	MB1.1: 30*130 H:30~50
-NAMUR Shaft	NEMA4	MG2:Mechanism Gilded Contact	2- M16*1.5		4- Flat 30°indicator	MB2.3:30*80(130) H:20~30
					5- Flat 45°indicator	
-Polyester Coating	NEMA4x	Proximity Sensors (Active)			6- Flat 60°indicator	Stainless steel(SS304 SS316) to choose
					7- Flat 120°indicator	
-Ni-p coating	CSA	PP:P&F(NAMUR) ExiallCT6			8-Three way valve "T" or "L"	
					9-ReverseRed-open Yellow-close	
		PA: Proximity Sensors(2or3)				
		Magnet Sensors (Passive)				
		QA:Magnet Sensors(2or3)				
		SPSTorSPDT				

Explosion Proof GKS-300 Series Limit Switch

Explosion Proof GKS-300 Series Limit Switch offers high-performance and stable product for high danger occasion. Aluminum or stainless body, polyester coating is deep and enduring. The body is accordance to E Ex standard.

Feature:

1. Two-dimension visual signal, high contrast color design, examine the position in all angle.
2. In accordance with NAMUR standard, promote interchangeability furthest.
3. Anti-proof bolt. It wouldn't drop when distuffing.
4. Aluminum or stainless body, polyester coating.
5. Double connection port: double 3/4" NPT port. It can maximum be chosen by 4 connection (G3/4", G1/2", 1/2"NPT, M20*1.5 to choose)
6. Multiple-connection terminal, eight standard connection. (many terminal to choose)
7. The cam installs by spline and spring. It can adjust quickly without tools.
8. Explosion proof: the body in accordance to Exd II CT6/BT6.



4-20mA Valve position transmitter selection picture

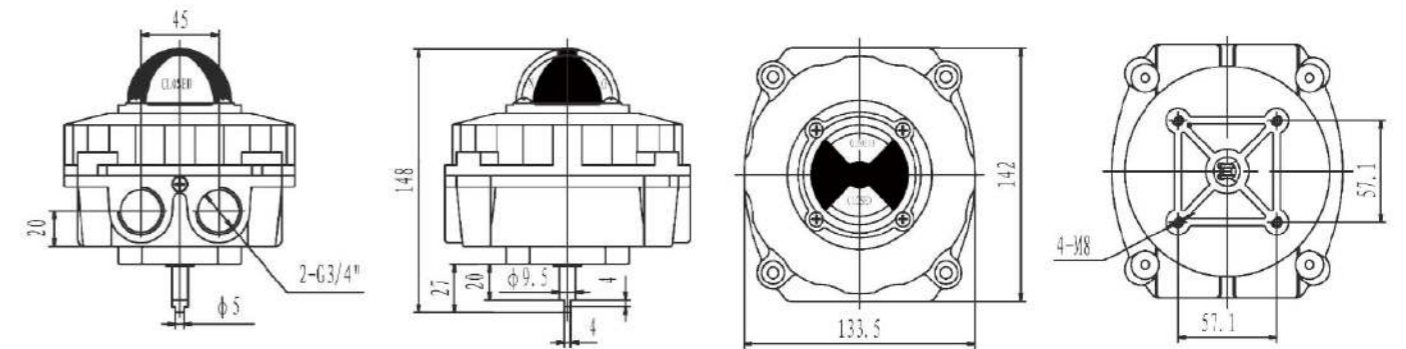

Selection Table

Optiona	Type	Switch	Wiring Port	External Wiring Position	Indicator	NAMUR Bracket (Carbon Steel)
-I prefix	GKS-300	Mechanical (passive)	2-G1/2"	2External Wiring Position	1- Dome 90°indicator	MB3.2:30*80 H:20
-Double D Shaft	Achieved Approval	M2:2SPDT	2-1/2"NPT	4External Wiring Position	2- Flat 90°indicator	MB3.3:30*80(130) H:20~30 H:50
		M3:3SPDT	2-M20*1.5	6External Wiring Position	3- Flat 30°indicator	
-NAMUR Shaft	Exia II CT6	M4:4SPDT	2-3/4"NPT		4- Flat 45°indicator	Stainless steel (SS304, SS316) to choose
		M5:2DPDT	2-G3/4"		5- Flat 60°indicator	
-Polyester Coating	ATEX	ML2:2SPDT-40°C	3 or 4port to choose		6- Flat 120°indicator	
		MG2:2SPDT			7- Three way valve "T" or "L"	
-Ni-p coating	IECEX	Proximity Sensors(active)	Magnet sensors	Extend option	8- Reverse Red-open Yellow-close	
		PP:P&F(NAMUR) ExiallCT6	QA:Magnet(2 or 3) SPST or SPDT	F:4~20mA Valve position feedback		
		PA:Proximity Sensors (2or3)				

Mechanical series GKEP-400 positioner

The series of mechanical GKEP-400 positioner uses the advanced structure and the technology of the standard item plug. It's reliable, precisely, convenient, easy. The double acting and single acting of product, positive and negative effect is easily switch. It has the features such as lower air consumption, easy range adjustment, quick respond speed, feedback stem connect easily.



Characteristics :

1. 5 ~ 200Hz in the range of non-resonance phenomenon.
2. Do not have replacement parts can be achieved 1 / 2 points within the scope of process control.
3. The zero adjustment and span adjustment is easily worked.
4. Forward and reverse, dual-role single-role and can be easily converted between.
5. Connecting with feedback stem is easy.
6. Response quickly and accurately.
7. Low air consumption, the economy is good.
8. For small executive body can reduce the positioning device to prevent shocks Orifice.

Selection Table

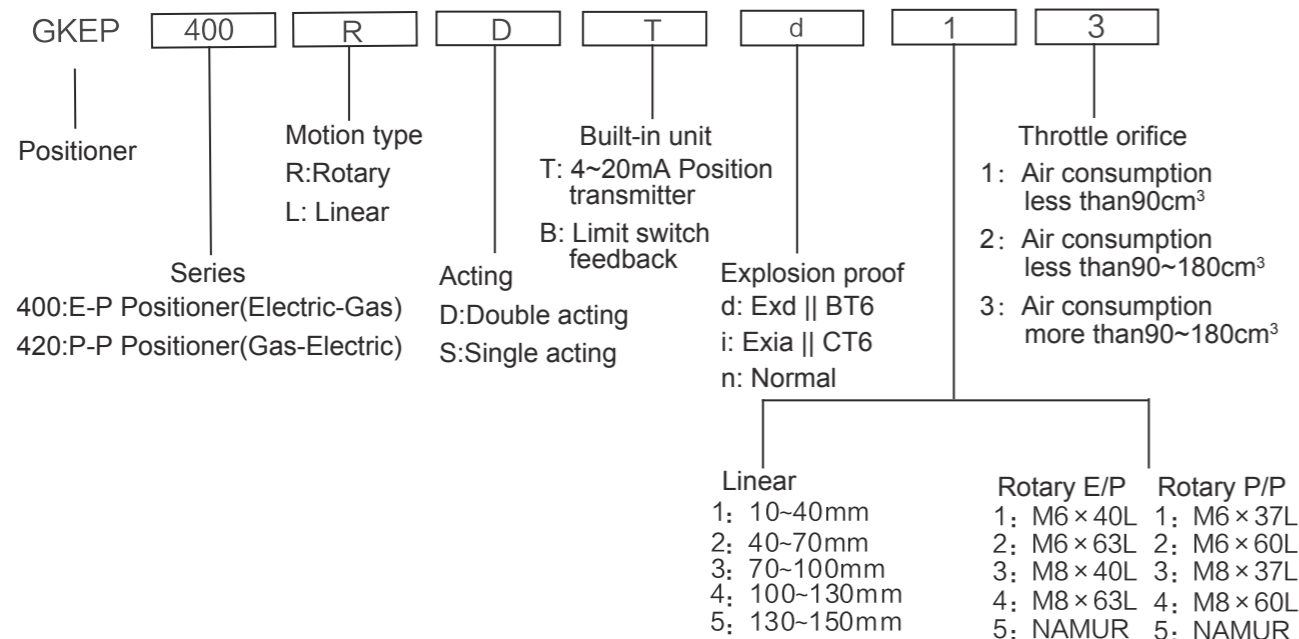

Additional switch options and technical issues, please consult the company.

Mechanical valve positioner

Technical parameters

Style	GKEP- 400	GKEP- 420
Input single	4~20mA DC	0.2~1kg/c m ² (3~15psi)
Resistance	250±15 Ω	
Input pressure	1.4~7kgf/cm ² (2~100Psi)	1.4~7kgf/cm ² (2~100Psi)
Motion range	0~90 ⁰ R, 10~150mm(L)	0~90 ⁰ R, 10~150mm(L)
Air port	G1/4" (NPT)	PT (NPT) 1/4"
Pressure gage port	ZG1/8" (NPT)	PT (NPT) 1/8"
Power supply port	G1/2"	
Explosion proof type	ExiaIIBT6 ExdIIBT6	
IP Grade	IP 65	IP 65
Temperature	-20℃~70℃	-20℃~70℃
Basic error	±1%	±2%
Return error	1%	1.5%
Dead time	0.4%	0.4%
Material	Die-cast Aluminum	Die-cast Aluminum
Weigh	2.8kg	1.7kg

Position Transmitters

Input type	2Wire
Input single	0° ~90 °
Output single	4~20mA DC
Resistance	0~600 Ω
Motion range	0~90 ⁰ R, 10~150mm(L)
Noise range	500mp.p
Adjustable range	Zero±10% Full 60~110%
IP Grade	IP 65
Linear error	±1%
Sensitivity	±0.2%
Return error	1%
Hysteresis	0.002
Supply voltage	15~30VDC
Explosion proof	Non-Explosion

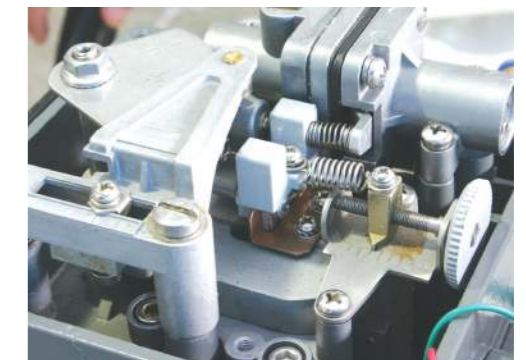

Built-in switch feedback

Explosion proof	5A125-250VAC
Electric switch	10~30VDC, ≤150mA
Magnetic switch	5~240VAC/DC, ≤300mA

Additional technical issues, please consult the company.

Smart GK-2300 series positioner

Smart GK-2300 series positioner is two-wire system instrument. It's widely used for the auto-control system of oil, chemical, electric, metallurgy, light industry and so on as supporting control unit.

Smart GK-2300 series positioner receives the input signal of 4-20 ma delivered into controller, and it exchanges the signal to set valves of valve position by A/D exchange. It receives the actual the signal of valve position at the same time. The above two signal calculate and handle by control software, so it can drive the valve position to set point by controlling the intake and exhaust of phenematics actuator.

Smart GK-2300 series positioner is the high-performance electricity /gas positioner that is based on micro processing technology. It can well overcome the friction and unbalanced force and promote the response speed of adjustment, for positioning quickly and correctly. It not only can replace traditional electricity/gas valve positioner, but also switch directly in the HART internet for achieving the exchange of controlling system's information.

Feature:

1. High accuracy, up 0.5% F.S
2. The operation is without opening the body, a high level of protection can operate locally.
3. Explosion-proof, safe and reliable.
4. Simple structure, small size, can install on a small actuator.
5. Auto-tuning, automatic diagnosis, the valve characteristic curve can configure by the settings.
6. Fewer mechanical parts, good resistance of resonance.
7. The parameter can set locally and remotely.
8. Low power consumption, low air consumption, low running costs.
- 9 two-wire 4 ~ 20mA standard signal.
10. Built-in lightning protection module, avoid the damage of lightning stroke.



Selection Table

Product option	GK-2300	<input type="checkbox"/>	<input type="checkbox"/>	<input type="checkbox"/>	<input type="checkbox"/>	<input type="checkbox"/>	<input type="checkbox"/>	<input type="checkbox"/>
Motion Type	Linear Rotary	<input type="checkbox"/>	<input type="checkbox"/>	<input type="checkbox"/>	<input type="checkbox"/>	<input type="checkbox"/>	<input type="checkbox"/>	<input type="checkbox"/>
Acting Type	Single Double	S D	<input type="checkbox"/>	<input type="checkbox"/>	<input type="checkbox"/>	<input type="checkbox"/>	<input type="checkbox"/>	<input type="checkbox"/>
Explosion Proof	Non Exd CT6	n d	<input type="checkbox"/>	<input type="checkbox"/>	<input type="checkbox"/>	<input type="checkbox"/>	<input type="checkbox"/>	<input type="checkbox"/>
Valve Position Feedback Output	4~20ma output Two way electronic switch output Two way route switch output Non	<input type="checkbox"/>	<input type="checkbox"/>	<input type="checkbox"/>	F T B 0	<input type="checkbox"/>	<input type="checkbox"/>	<input type="checkbox"/>
Communication	HART Non	<input type="checkbox"/>	<input type="checkbox"/>	<input type="checkbox"/>	H 0	<input type="checkbox"/>	<input type="checkbox"/>	<input type="checkbox"/>
External rotation opening indication	Rotation indication Non	<input type="checkbox"/>	<input type="checkbox"/>	<input type="checkbox"/>	R 0	<input type="checkbox"/>	<input type="checkbox"/>	<input type="checkbox"/>
Pressure gage module	Pressure gage Non	<input type="checkbox"/>	<input type="checkbox"/>	<input type="checkbox"/>	<input type="checkbox"/>	G 0	<input type="checkbox"/>	<input type="checkbox"/>
Fault protection	Reset Lock	<input type="checkbox"/>	<input type="checkbox"/>	<input type="checkbox"/>	<input type="checkbox"/>	<input type="checkbox"/>	0 1	<input type="checkbox"/>

Additional technical issues, please consult the company.

Smart valve positioner

Technical parameters

Gas Index	Air pressure	0. 14~0. 7 Mpa
	Valve leakage	<0. 6L / H
	Stable air consumption	<36L / H
Input and Output	Acting type	Single acting, double acting
	Motion range	Linear 10~100mm, Rotary 30~50°
	Electricity input	4~20mA Dc, minimum input electricity>3.6mA; Origin and destination of split control is settable
	Feedback output	4 ~ 20mA DC
	Switch input	Joint, Self-locking protection
	Switch output	2 way 24V 2A limit switch, 2 way electric switch
	Piezo Valve Switch frequency	fault-free action time over 2 billion in average
	Output characteristic correction	Liner, percentage (1:25, 1:33, 1:50), quick-opening- custom 20 curve for customer
Display Way	Communication	HART
	LCD	Two row seven position, size 22*38mm
	opening	0-100%, rotary opening display
Configuration Operation	Pressure gage	Two-three to choose, display the pressure of import and export
	Self-tuning	Self-tuning for zero,full scale,minimum dead-time, minimum prognosis
	Self-diagnosis	Diagnose for adjust, overrun, block an so on
Precision	Local operation	Three button in front panel, manual operate locally the switching of valve
	Dead-time	0.1~10% adjustable
	Linearity	0. 5%FS
	Sensitivity	0. 1%FS
Environment	Repeatability	0. 2%FS
	Temperature	-20 ~ 70°C
	Humidity	5 ~ 95%RH
	Shakeproof	15 ~ 150Hz / 2g
	IP Grade	IP65
Lightning Protection	Explosion proof	Exd CT6
	Protection level	Wire-wire: 65V Wire-ground: below 700V
	Response time	Wire-wire: below 4ns Wire-ground: below 20ns
	Output the lightning current	10KA~8/20 uS waveform
Configuration	Weight	2. 0 Kg
	Size	170 × 86x96 mm
	Shell material	Aluminum alloy